

User Manual

AGRETO AgriCounter Load

24.2.2020



Content

1	Introduction.....	3
2	Scope of delivery	3
3	Intended use.....	3
4	Security	3
4.1	Safety instructions for the buyer.....	3
4.2	Safety instructions for the operator	4
4.3	Personal protective equipment	4
4.4	Residual risks.....	4
5	Technical specifications	5
6	Configuration	5
6.1	Selection of the operating mode.....	5
6.2	Operating Keys	6
6.3	Setting the operating mode	6
6.4	Process of detecting a load	7
6.5	Setting the parameters.....	8
6.6	Zeroing the counter.....	12
7	Assembly	13
7.1	Positioning of the meter	13
7.2	Fixing the mounting plate.....	13
7.3	Fastening the counter	14
7.4	Attaching the seal	14
8	Working with the device.....	15
8.1	Reading the loads.....	15
8.2	Reading the hours	15
8.3	Symbols on the display.....	16
9	Maintenance and cleaning	17
10	Troubleshooting.....	17
10.1	The battery symbol lights up	17
10.2	Loads are not counted completely	17
10.3	Too many loads are counted.....	17
10.4	Operating hours are not counted completely	18
10.5	Too many operating hours are counted	18
10.6	Damage to the device	18
11	Warranty	19
12	Disposal.....	19
13	Imprint.....	20

1 Introduction

Thank you for choosing an AGRETO AgriCounter Load. You have acquired a robust tool for daily use.

Please read this manual carefully before using the equipment.

2 Scope of delivery

- 1 Display unit
- 1 Mounting plate
- 2 AAA batteries
- 5 Seals
- Mounting parts
- Manual

3 Intended use

The AGRETO AgriCounter Load is designed for the counting of loads on slurry tanks with level indicators and transport vehicles with moving parts.

The activation takes place by the determination of sequences of position changes of the counter. Depending on the setting, the operating hours are also determined.

4 Security

4.1 Safety instructions for the buyer



Important!

Make sure that every person who works for the first time with the AGRETO AgriCounter, has read and understood this manual.

4.2 Safety instructions for the operator



DANGER!

The AGRETO AgriCounter may only be operated by persons who are familiar with the operation of the device.



CAUTION!

Keep the work area clean! Soiled areas contributes to accidents.



RISK!

Risk of injury from tip-over / fall and inattention while working with the measuring instrument during getting on and off the tractor.

4.3 Personal protective equipment



WARNING!

For individuals who work with the device or reside in the working area the wearing of safety shoes are required.

4.4 Residual risks

When using the device residual hazards for persons and objects may occur that can't be prevented by design or technical protection measures.



WARNING!

The AGRETO AgriCounter must not be operated in explosive areas.

5 Technical specifications

- Packaging dimensions: 220x160x50 mm (LxWxH)
- Package weight: 450 g
- Device dimensions: 73 x 52 x 33 mm (WxHxD)
- Weight: 230 g
- Dust and waterproof plastic housing
- 3 internal control buttons for configuration
- Six-digit display with 11 mm digit height
- Icons for displaying additional information
- Powered by 2 x AAA batteries
- Battery life approx. 3 years

6 Configuration

6.1 Selection of the operating mode

The AGRETO AgriCounter Load has 2 operating modes. In the first mode, only the amount of loads are counted, in the second mode additionally the working hours are counted.

First, decide which operating mode is suitable to your application, set the required settings if necessary, and then mount the counter on your machine!

Overview of the modes:

Operating mode	Output	Activation by
3 A (default)	Loads	Location / sequenz
3 B	Loads Operation hours	Location / sequenz Vibration / movements

6.2 Operating Keys

The control buttons are located inside the device and accessible from the back with the mounting plate removed.

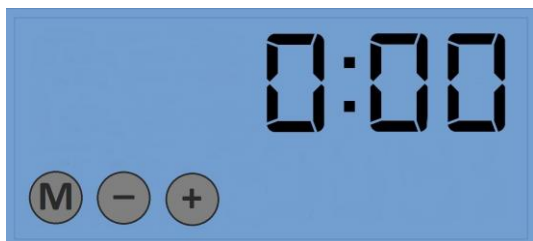

To change settings, look at the buttons and then turn the device with the display to the front to read the display.

Button	Definition	Function
M	Menu	Entry into the menu Continue to the next parameter, exit from the menu
-	Minus	Back to the previous step Decrease a parameter by 1
+	Plus	Continue to the next step Increase a parameter by 1

6.3 Setting the operating mode

On delivery, the operating mode 3A is preset.

To change the operating mode, press and hold the "M" button for 3 seconds. After releasing the key, the display briefly shows "MOdE" and then the current setting of the operating mode appears.

Change to the desired operating mode with the "+" or "-" buttons.

The "M" key (or if you wait 10 seconds) will save the selection and exit the menu.

Please note: Changing the operating mode will reset all totals to 0.

6.4 Process of detecting a load

To count a load, you have to go through a certain sequence of angular positions. In addition, minimum times must be reached in order to exclude a multiple count.

For a slurry tanker with level indicator (pointing to the left) this looks like the following example:

- The counter is mounted directly on the level indicator, the angle of the level indicator is identical to the angle of the device. The angle is measured and evaluated by the device.
- A tanker starts with the first load, the level indicator is set to "empty", the angle is below the middle. The counter is in the "empty" state.
- The filling process starts, the level indicator turns upwards.
- If the tank is approximately half full, the angle set in parameter "A1" is exceeded. Now the time "t1" set in the parameter starts to run. This status is indicated by the up arrow.
- The filling process continues. The counter checks whether the pointer is above the angle "A1" at least the entire time "t1". If this is the case, the filling is considered completed. The counter changes to the status "full".
- The tanker moves to the unloading point.
- The unloading process starts, the level indicator turns down.
- If the tank is approximately half empty, the angle fall below the setting in parameter "A1". Now the time "t2" set in the parameter starts to run. This status is indicated by the down arrow.
- The unloading process continues. The counter checks whether the pointer is below the angle "A1" at least the entire time "t2". If this is the case, the application is considered completed, a load is counted. The counter changes to the "empty" state and the sequence starts again.

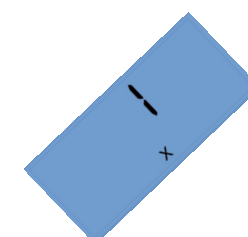
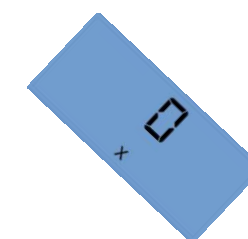
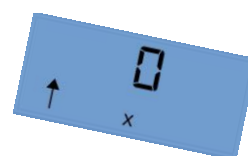
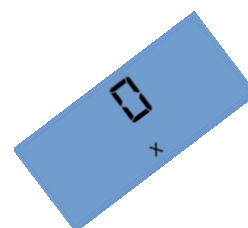

6.5 Setting the parameters

For the correct registration of the loads, the parameters for position and angle may need to be adjusted. In mode 3B the additional parameters for time recording are available.

To open the parameter menu, briefly press the "M" key. The first parameter that is relevant for the set operating mode appears on the display.

The name of the parameter is displayed for two seconds, then the set value appears.

Use the "+" or "-" keys to change the value of the parameter.

Use the "M" key to change to the next parameter, the set value is saved. After the last parameter, the first parameter is displayed again.

To exit the menu, press and hold the "M" button for three seconds, or simply wait 10 seconds without pressing a button.

Parameter dir - Direction

This parameter sets the direction in which the level indicator on which the AgriCounter is mounted is aligned.

LeFt = Level indicator points to left (Presetting)

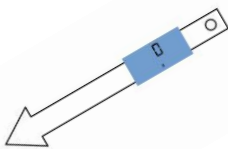

Righ = Level indicator points to right

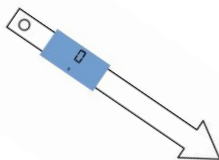

AGRETO AgriCounter Load

Parameter A1 – Center angle of the pointer

This parameter sets the angle of the level indicator in its center position. This angle distinguishes between full and empty.

0 = default (pointer is horizontal)

90 = maximum adjustable angle (pointer is vertically upwards)

-90 = minimum adjustable angle (pointer is vertically downwards)

Example:

Angle of the pointer when the tank is empty: -40 degrees

Angle of the pointer when the tank is full: 60 degrees

= Center position: 10 degrees

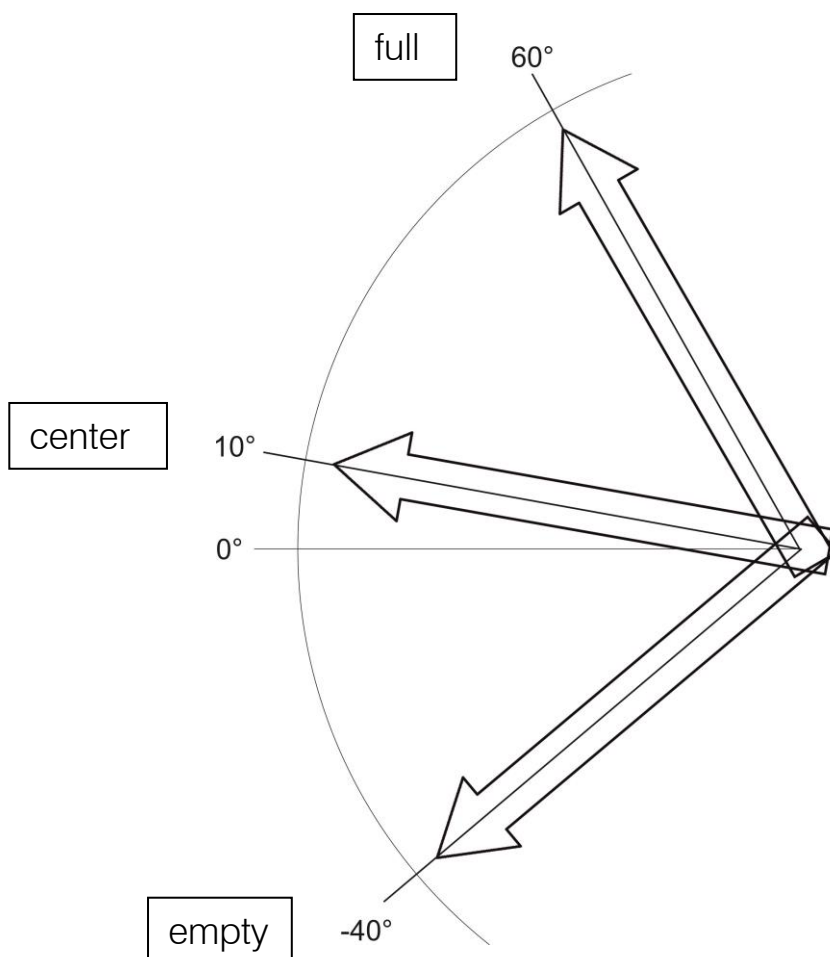

AGRETO AgriCounter Load

Parameter t1 – Time above the center position

This parameter sets how long the pointer must be in total above the center position to reach the "full" state.

This time prevents a double count of a load when the pointer fluctuates. It should not exceed half the filling time, the shortest journey to the unloading point and half the emptying time.

If the time is set too high, the load will not be counted. If the time is set too low there is a risk that an additional load will be counted if the pointer fluctuates.

1 = lowest settable time in seconds

60 = default

1000 = maximum settable time in seconds

Parameter t2 – Time below the center position

This parameter sets how long the pointer must be in total below the center position to reach the "empty" state.

This time prevents a double count of a load when the pointer fluctuates. It should not exceed half the emptying time, the shortest journey to the loading point and half the filling time.

If the time is set too high, the load will not be counted. If the time is set too low there is a risk that an additional load will be counted if the pointer fluctuates.

1 = lowest settable time in seconds

60 = default

1000 = maximum settable time in seconds

AGRETO AgriCounter Load

Parameter SENS - Sensitivity (operating mode 3B)

This parameter determines from which intensity of a movement the count is triggered, ie how strong the vibration or movement must be. The higher the value, the stronger the movement must be to trigger or continue the count.

0 = highest sensitivity (counts even on very small movements)

2 = a running internal combustion engine is already detected

4 = default

10 = lowest sensitivity (only counts for extreme movements)

The parameter SENS is related to the parameter hoLd, since a movement must always have a certain intensity and must be present for a certain period of time in order to trigger the summation.

Parameter hoLd – Holding time (operating mode 3B)

In idle mode, this parameter determines the time in seconds that the counter waits after a first move to actually start the totalization permanently. If there is another movement within the set time (which is strong enough), the time from the first movement is added up and the counter is in counting mode. If there is no further movement within the set time, the counting is stopped and the sum is reset to the initial value.

1 = summation starts immediately after the first movement

20 = default

100 = summation is started after 100 seconds

In counting mode, this parameter determines the length of a rest period in seconds, during which the count continues without interruption. If another movement follows within the set time (which is strong enough), the complete time is added up, including the rest phase. If the rest period lasts longer than the set time, the count stops and the sum is reset to the value at the beginning of the rest phase. The meter is now in idle mode.

1 = summation is stopped immediately at the end of the movement

20 = default

100 = A rest period of up to 100 seconds is counted

AGRETO AgriCounter Load

Parameter Unlt - Display format (operating mode 3B)

This parameter determines the format of the hour display.

00:59 = default setting, display in hours and minutes (hhhh:mm)

00,99 = display in hours with 2 decimal places (hhhh,hh)

By default, the display is in hours and minutes, and the colon is used as the separator.

If necessary, you can change the display to decimal hours, here the comma is used as separator.

6.6 Zeroing the counter

To reset the counter, press and hold all 3 buttons together for 3 seconds. When released, all totals are set to 0.

7 Assembly

Only start with the assembly once you have clarified whether a change in the configuration is necessary for your application. Please read the chapter "Configuration" before.

7.1 Positioning of the meter

The most common application for the AgriCounter Load is the installation directly on the level indicator of a slurry tanker. It is not a problem if the level indicator is narrower than the housing of the AgriCounter.

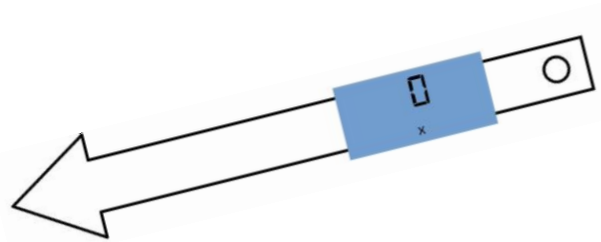

The assembly is also possible on any moving part, which is once per deployed load in a certain angular position, for example, on an actuating linkage or a discharge hatch or cover.

7.2 Fixing the mounting plate

- On delivery, the meter is mounted on the mounting plate. Disassemble the meter from the mounting plate.
- Hold the mounting plate in the desired position to the desired mounting position.
- Use the mounting plate as a template and mark the 2 holes with a pin.
- Hit one notch each with a grain.
- Drill the 2 holes with a 4.2 mm diameter drill.
- Deburr the 2 holes.
- Use a M5 screw tap to cut a thread in each hole.
- Use the 2 M5x25 allen screws and the 2 aluminum washers and screw the base plate to the machine. Note that the sealing surface of the base plate is pointing towards the meter.

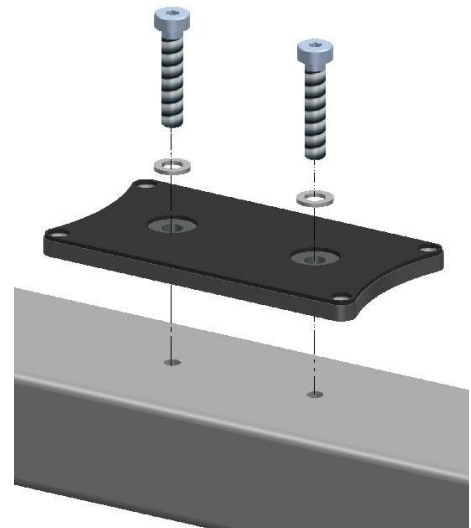

7.3 Fastening the counter

- Place the counter on the base plate.
- Use the 4 allen screws M5x8. Two of them have a small hole for the seal wire, use these two on the side where you want to attach the seal.
- First, pull slightly down all 4 screws, and then tighten every screw again so that the housing is evenly pressed against the mounting plate.

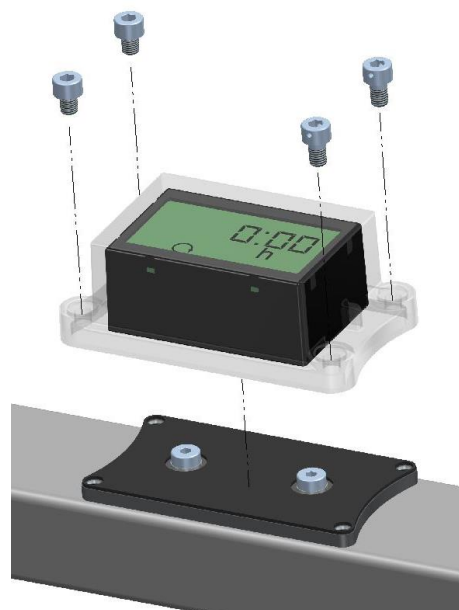

7.4 Attaching the seal

- Thread the seal wire through the holes in the two screws.
- Thread both ends of the wire through a hole in the seal.
- Slide the seal as close as possible to the meter and at the same time tighten the wire.
- Close the seal.

If the hole of one of the screws is not accessible, you can also drill a small hole in the housing bar between the two screws and pull through the seal wire here.

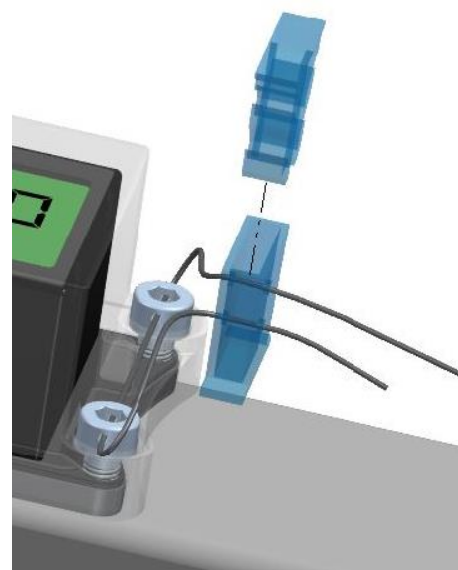

8 Working with the device

8.1 Reading the loads

The AgriCounter Load permanently displays the sum of the counted loads, an operation for reading is not provided.

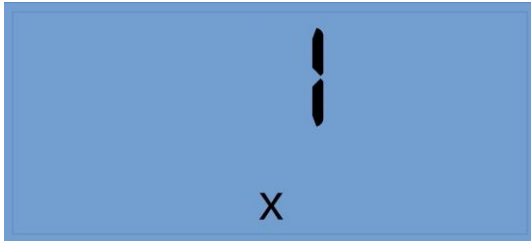

The symbol X indicates that the displayed number is the sum of the loads.

8.2 Reading the hours

The AgriCounter Vibration permanently displays the sum of the counted hours, an operation is not provided for reading.

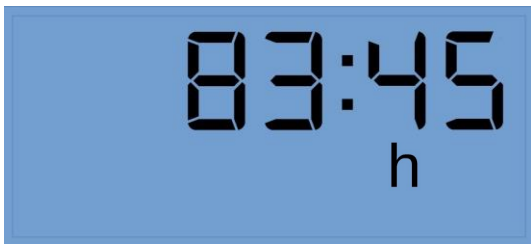

If the colon is visible as a separator, it is hours and minutes.

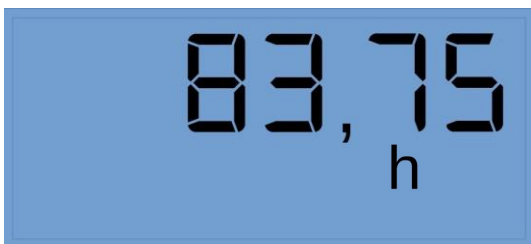









If the comma is visible as a delimiter, it is decimal with 2 decimal places.

The display is updated every 5 seconds.

8.3 Symbols on the display



Below the main display there are various icons for displaying additional information.

-  The down arrow means that the currently displayed hours refers to the working time (device down = working position).
-  The up arrow means that the currently displayed hours refers to the transport time (device up = transport position).
-  The wavy line means that the counter is currently detecting movement or vibration and is in counting mode.
-  The x means, that the displaying of the loads is active
-  The h means that the displaying of the hours is active.
-  The s lights up in the setting mode when a parameter value is expected in seconds.
-  The crossed-out battery icon lights when the batteries are low and you need to replace them.
-  The angle symbol lights up in the setting mode when a parameter value in degrees is expected.

9 Maintenance and cleaning

The AgriCounter basically does not require ongoing maintenance.

- If the display is dirty, clean it for reading.
- If the battery symbol is lit, replace the batteries.

10 Troubleshooting

10.1 The battery symbol lights up

The batteries need to be replaced, follow these steps:

- Remove the seal and the seal wire.
- Remove the housing and remove the meter.
- Remove the old batteries and dispose them properly.
- Insert 2 new AAA batteries into the device in the specified direction.
- Mount the counter again on the mounting plate.
- Seal the device again with a new seal wire and a new seal.

10.2 Loads are not counted completely

It is likely that the sequenz for counting a load will not be completed.

- Check the set angle **A1** for the center position.
- Make sure that the set times **t1** and **t2** are safely reached, reduce times when needed.

10.3 Too many loads are counted

It is likely that parts of the sequenz for counting a load will be skipped.

- Check the set angle **A1** for the center position.
- Make sure that the set times **t1** and **t2** are sufficiently high that fluctations of the device by the middle angle do not lead to counting additional loads. Increase times when needed.

10.4 Operating hours are not counted completely

The movements or vibrations on the machine are probably relatively low, so that the necessary intensity for the count is not reached.

- Set the parameter **SENS** down so that the counter triggers even with minor movements.
- To hold longer periods of rest during operation, set the parameter **hOLd** upwards.

10.5 Too many operating hours are counted

Perhaps the machine is exposed to light movements at standstill, which are recorded as operating hours.

- Set the parameter **SENS** upwards so that the counter only triggers for larger movements
- To prevent idle phases from being counted during operation, set the **hOLd** parameter down.

10.6 Damage to the device

- Contact the manufacturer or your dealer

11 Warranty

In addition to the statutory warranty, the following warranty conditions apply to the AGRETO AgriCounter Load:

- The AGRETO electronics GmbH guarantees the function and repairs or replaces all the parts that have a material or manufacturing damage within the warranty period.
- Warranty services will be performed by the AGRETO electronics GmbH.
- The decision on the existence of a warranty claim is sole responsibility of the AGRETO electronics GmbH.
- The warranty period begins with the first accounting to an end customer and ends 5 years from this date of invoice.
- Prerequisite for warranty service are the presentation of the original invoice and compliance with all elements of this instruction manual.
- Excluded from warranty are wear, normal wear and tear, damage due to misuse, negligence or accident.
- When processing a warranty claim transport costs incurred will be charged to the buyer.

12 Disposal



Dispose of the device as part of the final shutdown or parts of it environmentally friendly and sorted (metal to the respective metal scrap, plastic to the plastic waste, etc. - do not dispose as household waste)!

Detailed information can be found in directive 2002/96 / EC

13 Imprint

All information, specifications and illustrations are as of 2020, subject to technical changes or design changes.

All information in this manual are supplied without liability despite careful preparation. A liability by the author is excluded.

Copyright © 2020, AGRETO electronics GmbH

AGRETO electronics GmbH
Pommersdorf 11
A-3820 Raabs

Tel.: +43 2846 620

Fax: +43 2846 620 19

E-Mail: office@agreto.com

Internet: www.agreto.com